

Robotic Pool Cleaner

CX40
CX50

TYPE EB37--

⚠ WARNING

FOR YOUR SAFETY – For anything other than the routine cleaning and maintenance described in this guide, this product must be serviced by a qualified professional with sufficient experience in pool equipment installation and maintenance so that all of the instructions in the product's complete installation and operations manual can be followed exactly. All safety instructions in the complete manual must be followed explicitly in order to prevent injury hazards. Improper installation and/or operation may void the warranty. Never turn the cleaner on unless it is fully submerged in the water. Doing so may void the warranty and may cause severe damage to the cleaner motors.



WARRANTY REGISTRATION	Record your equipment details here for quick reference: Model No.: _____ Serial No.: _____
	AUSTRALIA WARRANTY: For full warranty terms and conditions and to register your warranty, visit www.zodiac.com.au/warranty and complete your details. ◀ Or scan the QR code to go directly to the registration page.
	NEW ZEALAND WARRANTY: For full warranty terms and conditions and to register your warranty, visit www.zodiac.co.nz/warranty and complete your details. ◀ Or scan the QR code to go directly to the registration page.

Table of Contents

Section 1. Important Safety Instructions.....	4	Section 5. Maintenance.....	9
Section 2. Cleaner Specifications	5	5.1 Cord Tangling	9
2.1 General Specifications	5	5.2 Clean the Filter Canister.....	10
2.2 Contents.....	5	Section 6. Cleaner Storage	11
Section 3. Getting Started.....	5	Section 7. Replacing Wear Parts.....	11
3.1 Transport Caddy (CX50 only)	5	7.1 Replacing Brushes	11
3.2 Connect to a Power Source.....	6	7.2 Replacing Tracks.....	12
3.3 Submerge the Cleaner	7	Section 8. Troubleshooting	14
Section 4. Control Unit	8	8.1 Error Codes.....	14
4.1 Start / Stop Cleaning.....	8	8.2 Deleting an error code.....	14
4.2 Lift System	8	8.3 General Troubleshooting	15

Section 1. Important Safety Instructions

READ AND FOLLOW ALL INSTRUCTIONS

Please read through the entire manual before installing your new pool cleaner.

WARNING

Failure to comply with the following warnings can result in permanent injury, electrocution or death.

PREVENT ELECTRICAL SHOCK

To reduce risk of electrical shock:

- Please read the manual carefully, especially the safety instructions, and make sure you understand them fully before using the product. Only use the equipment for the purposes specifically intended by the manufacturer. Carefully follow the instructions on operation, maintenance and repair.
- This Cleaner is not suitable for use by children and people with reduced physical, sensory or mental capabilities or inexperienced people who are not familiar with the product. Children should be supervised to ensure that they do not play with the appliance, even when it is not in operation.
- Operators who perform maintenance must be fully conversant with its special features and safety regulations. Before using the cleaner, carefully read the operating manual and make sure you understand the instructions.
- Only use original spare parts, do not change the design of the Cleaner, do not remove, bypass or tamper with the safety devices installed. The manufacturer shall not be held liable if non-original spare parts are used. Failure to comply with this requirement may seriously endanger the health and safety of people.
- Ensure the cleaner is turned off before performing any adjustment or maintenance that the user is authorized to perform. Cleaning and maintenance must not be performed by children.
- Do not use the cleaner if the top cover or brushes are damaged.
- The product contains magnets and components that emit electromagnetic fields. The magnets and electromagnetic fields can interfere with pacemakers, defibrillators and other medical devices. Keep a safe distance between the medical device and the product. Consult your doctor or the manufacturer of the medical device for specific information about it. If you think that the product is interfering with a pacemaker, defibrillator, or any other medical device, stop using the product starting from the distance at which you feel interference.

WARNING

- Do not enter pool while the Zodiac pool cleaner is in water.
- Double insulation—For continued protection against possible electric shock, use only identical replacement parts when servicing. Do not attempt repair of the Zodiac robotic cleaner, charging station, or power cord.

PREVENT CHILD INJURY AND DROWNING

- To reduce the risk of injury, do not permit children to operate this product. The appliance is not a toy for children.
- Do not let anyone, especially small children, sit, step, lean, or climb on any equipment installed as part of your pool's operational system.

CAUTION

Failure to comply with the following warnings could cause damage to pool equipment or personal injury.

- The Zodiac cleaner must be installed and operated as specified.
- This product is intended for use with permanently-installed pools. Do not use with storable pools. A permanently-installed pool is constructed in or on the ground or in a building such that it cannot be readily disassembled for storage. A storable pool is constructed so that it is capable of being readily disassembled for storage and reassembled to its original integrity.
- Clean the filter canister in the Zodiac cleaner after each use.
- Do not use the product in your pool if the water temperature is above 35°C or below 13°C.

USE OF THE ZODIAC ROBOTIC CLEANER IN A VINYL LINER POOL

- Certain vinyl liner patterns are particularly susceptible to rapid surface wear or pattern removal caused by objects coming into contact with the vinyl surface, including pool brushes, pool toys, floats, fountains, chlorine dispensers, and automatic pool cleaners. Some vinyl liner patterns can be seriously scratched or abraded simply by rubbing the surface with a pool brush. Ink from the pattern can also rub off during the installation process or when it comes into contact with objects in the pool. Zodiac Group Australia Pty. Ltd. is not responsible for, and the Limited Warranty does not cover, pattern removal, abrasion or markings on vinyl liners.

SAVE THESE INSTRUCTIONS

Section 2. Cleaner Specifications

2.1 General Specifications

The general specifications for the cleaner are as follows:

Control Unit supply voltage	220-240 VAC, 50 Hz, short circuit-proof safety isolating type
Cleaner voltage	30 V DC
Installed load	150 W max
Cable length	18m (CX50) 15m (CX40)
Cleaner size (WxDxH)	43 x 48 x 27 cm
Weight of Cleaner	9.5 kg
Packed weight	19 kg (CX50) 14 kg (CX40)
Filtration	Dual filter canisters
Cycle lengths	2h 30m (all surfaces) 1h 15m (floor only)

The cleaner is a double-insulated product. A double-insulated electrical appliance is one which has been designed in such a way that it does not require a safety connection to ground. The basic requirement for double-insulation is that no single failure can result in dangerous voltage becoming exposed so that it might cause an electric shock and that this is achieved without relying on an earthed (grounded) metal casing. This is achieved by having two (2) layers of insulating material surrounding live parts or by using reinforced insulation. Therefore, devices having double-insulated construction, such as this cleaner, do not use a grounded (three-prong) cord/plug.

2.2 Contents

The packaging should contain the following items:

- Robotic cleaner and floating cable
- Control Unit
- Printed materials
- Transport and storage caddy (CX50 only)

Section 3. Getting Started

3.1 Transport Caddy (CX50 only)

1. Assemble the caddy using the separate instructions included.
2. Press Control Unit onto the caddy hook until it snaps and locks into position

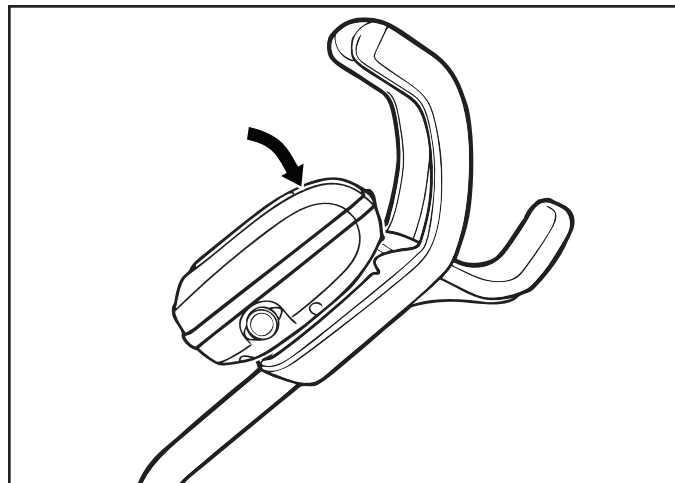

Figure 1. Attach Control Unit to Caddy

Refer to the trolley assembly document for trolley assembly instructions.

3.2 Connect to a Power Source

⚠ WARNING

Failure to comply with the following warnings can result in permanent injury, electrocution or drowning.

PREVENT ELECTRICAL SHOCK AND FIRE

- Keep the Control Unit at least 3.5 m from the edge of the pool.
- The cleaner is to be installed in accordance with the relevant requirements of the Australian wiring rules AS/NZS 3000. Also refer to the installation instructions relating to the swimming pool equipment for which the cleaner will be an integral part. The cleaner is to be supplied through a Residual Current Device (RCD) with a rated residual operating current of 30mA.
- Do not use an extension cord to connect the Control Unit.
- The Control Unit is water-resistant, not waterproof. In order to prevent electrocution, never submerge the Control Unit or leave exposed to inclement weather.
- Do not enter pool while the robotic cleaner is in water.
- Do not bury cord. Locate cord so as to prevent it from being damaged by lawn mowers, hedge trimmers and other equipment.
- To reduce the risk of electrical shock, do not use the robotic cleaner or Control Unit if the cord is worn or damaged. Contact Zodiac Customer Care Service at 1300 763 021 for Australia or 0800 807 665 for New Zealand immediately for proper servicing and replacement of the damaged cord.

⚠ CAUTION

To prevent damage to the cleaner, be sure to adhere to the following guidelines:

- Remove the cleaner from the pool after the cleaning cycle is completed.
- Store out of direct sunlight or inclement weather.
- Never lift the cleaner out of the pool by the floating cable.
- Take additional care when lifting the cleaner out of the pool. It becomes heavier when filled with water.
- Always remove the cleaner from pool when super chlorinating or adding acid.
- Do not handle cleaner while it is in operation.
- Ensure that the cleaner is not in running mode before handling.

IMPORTANT

- Always make sure the cleaner head is fully submerged before you begin operation.
- Clean the filter canister after each cleaning cycle.
- At the end of each cycle, remove the cleaner from the pool.
- Do not leave your cleaner in the pool on a permanent basis.
- Start at the cleaner head and untangle any coils in the cable before storing the cleaner.

The Zodiac robotic cleaner includes a safety feature that automatically stops the cleaner if it is powered on but not submerged in water. For pools equipped with a beach area, this safety feature is programmed to drive the cleaner in reverse and back into the pool when the impeller is out of the water.

1. Unscrew the protective cap for the floating cable from the side of the Control Unit by turning counter-clockwise.
2. Grip the notched end of the floating power cable, insert into the Control Unit and click to lock.

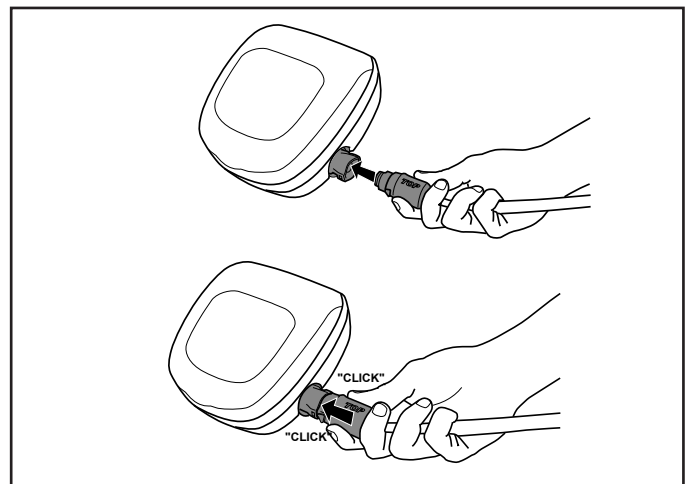

Figure 1. Connect Power Cable

Plug the control unit into a 240V residual current device, keeping the control unit at least 3.5 m away from the pool.

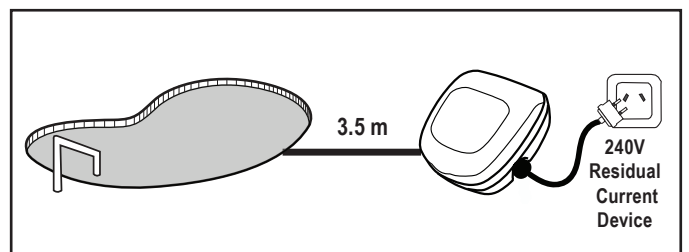

Figure 2. Plug in Control Unit

3.3 Submerge the Cleaner

1. With the Control Unit plugged into a power outlet, spread the floating cable across the pool deck until you reach the middle of the pool length.
2. At the center point, submerge the cleaner in the pool and hold in the vertical position to release any air trapped inside

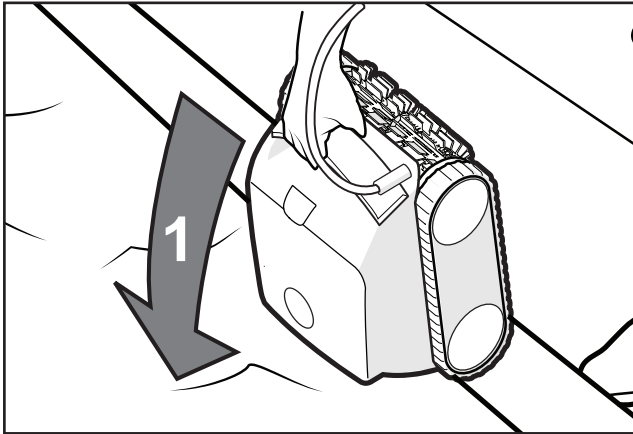

Figure 3. Submerge the Cleaner Vertically

3. Ensure the unit sinks to the bottom of the pool and does not float (Figure 12).

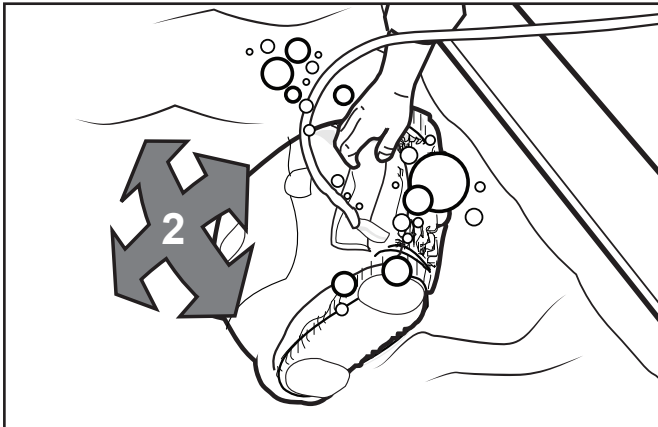

Figure 4. Cleaner Sinking to the Bottom of the Pool

4. Place only enough floating cable in the water to reach the farthest end of your pool from the central point. Spread out the floating cable ensuring there are no kinks or coils.

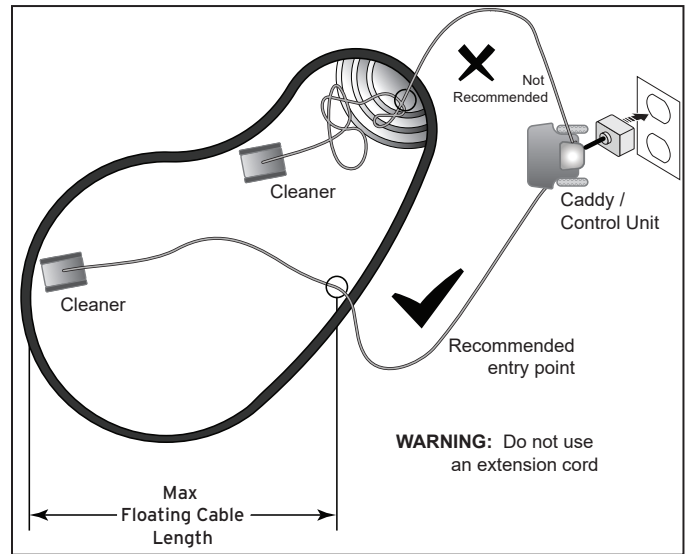

Figure 5. Cable Placement



Never swim when cleaner is in the pool

Section 4. Control Unit

The Control Unit can be used to initiate basic cleaning features.



	Starts/Stops cleaning
	Selects cleaning mode:
	Floor/Walls/Waterline mode 2h 30 min cycle (default mode)
	Floor Only mode 1h 15 min cycle
	Drives the cleaner to the pool edge for retrieval (CX50 only)

4.1 Start / Stop Cleaning

With the cleaner submerged in the water:

- Press to begin the cleaning cycle.
- Press again to stop the cleaning cycle.
- Press to toggle between cleaning modes:
 - Floor/Walls/Waterline (2h 30 min)
 - Floor Only (1h 15 min)

NOTE: The Control Unit goes into standby after 5 minutes and the display turns off. The cleaner will continue to function in standby mode. Press any key to exit standby mode.

1. When the cleaning cycle is done, remove the cleaner from the pool using the handle.

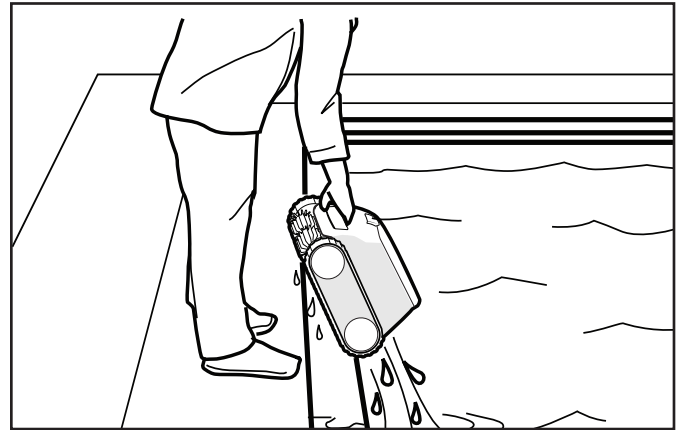

Figure 6. Always remove cleaner using the handle

NOTE: Never lift the cleaner out of the pool by the floating cable.

4.2 Lift System (CX50 only)

The Lift System is designed to assist in retrieving the robot from the pool. Lift System can be activated at any time during or after a cleaning cycle.

1. Press to begin the automated procedure to bring the cleaner to the wall.

NOTE: To stop the procedure at any time, press and release the button again.

2. Next, Press and HOLD to rotate the cleaner.
3. Once the cleaner is facing the wall of your choice for retrieval, release the button.
4. Cleaner will drive forward and up the wall it is facing. It will wait at the waterline to be retrieved.
5. When in reach, remove the cleaner from the pool using the handle.

Section 5. Maintenance

The cleaner should be cleaned regularly using mild soapy water. Do not use any solvents such as trichlorethylene. Rinse using clean water. Do not let the cleaner dry in direct sunlight near the pool.

⚠ WARNING

To avoid electric shock and other hazards which could result in permanent injury or death, disconnect (unplug) the cleaner from the power source before performing any cleaning and maintenance.

5.1 Cord Tangling

Tangling can occur more frequently when the cleaner is not attended to after each cleaning cycle. General maintenance and the following troubleshooting steps can help to avoid cable challenges.

IMPORTANT

Cleaner power cable may become tangled if correct procedure is not followed after each cleaning cycle.

NOTE: For optimal patterning and reduced tangling, the floating cable should enter the water near the middle of the pool length. Only place enough cable in the water to reach the farthest point in the pool.

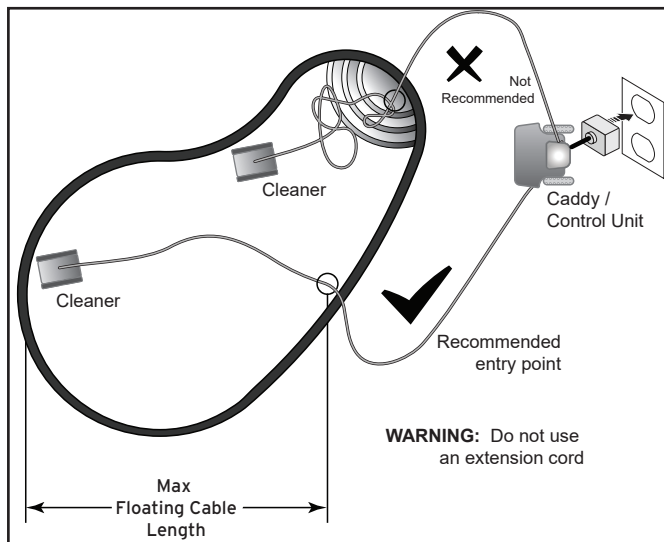

Figure 7. Cable Placement

If tangling occurs, follow these steps:

1. If equipped, use the Lift System to drive the cleaner to the waterline. Remove the cleaner from the pool using the handle.

2. Hold the cleaner vertically to drain.

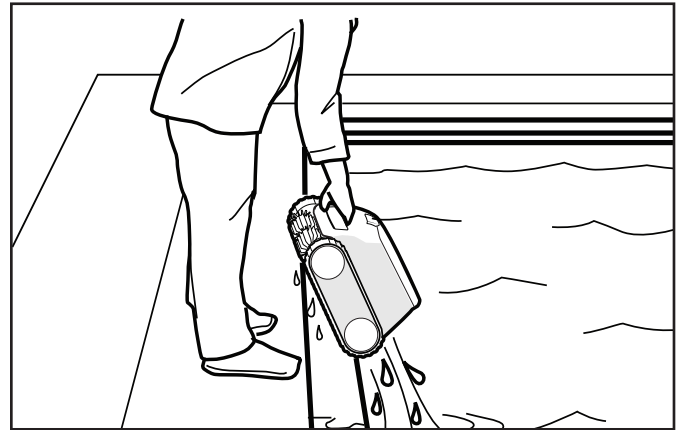

Figure 8. Keep Cleaner Vertical to Drain Water

3. Unplug power to the cleaner at the Control Unit.

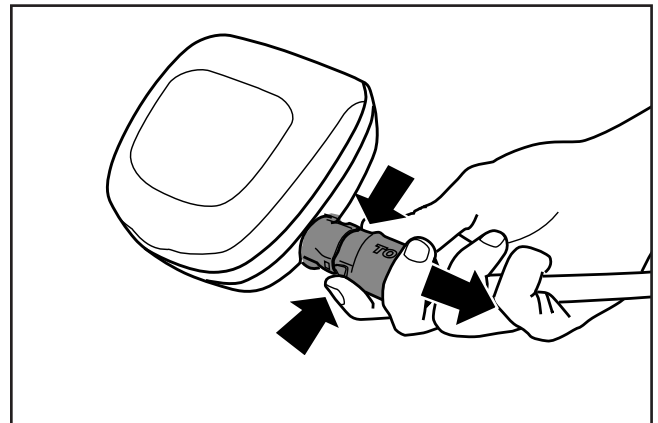

Figure 9. Unplug power

4. Untangle all kinks and coils in the power cable. Start at the cleaner head. Lay the cable in the sun to loosen any tangling memory.

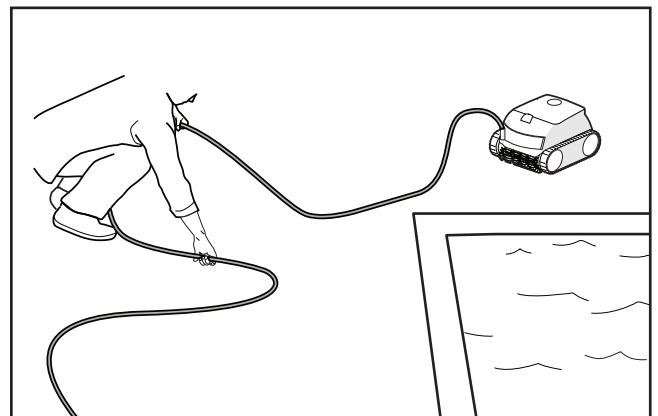

Figure 10. Untangle the power cable

5.2 Clean the Filter Canister

The filter canister should be cleaned at the end of each cycle.

1. If equipped, use the Lift System to drive the cleaner to the waterline. Remove the cleaner from the pool using the handle.
2. Set the cleaner on the deck and let the remaining water drain.
3. Push the cover lock and lift the cover until it is secured in the vertical position.

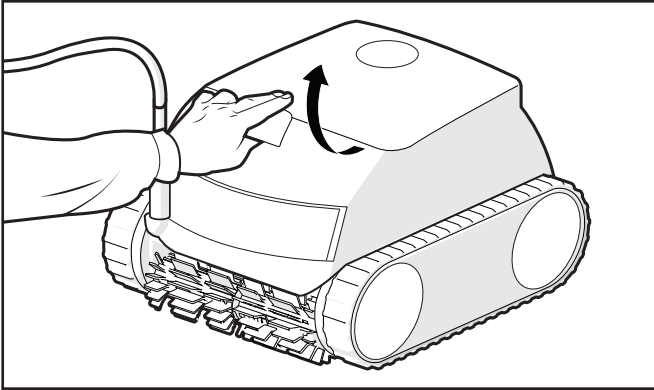

Figure 11. Lift Cleaner Cover

4. Remove the filter canister assembly from the body.

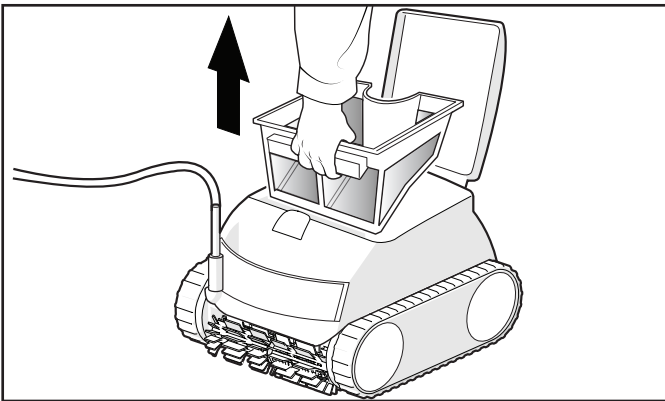

Figure 12. Remove Filter Canister

5. Pull down on the outer canister to separate the two filters.

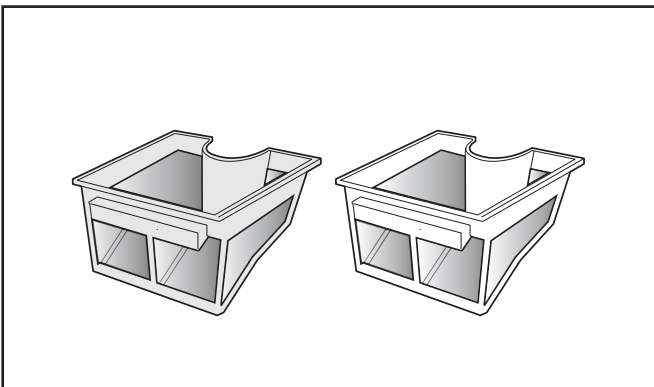

Figure 13. Dual Filtration Canisters

6. Empty all debris from the filter canisters, then rinse canisters and the cleaner using a hose.

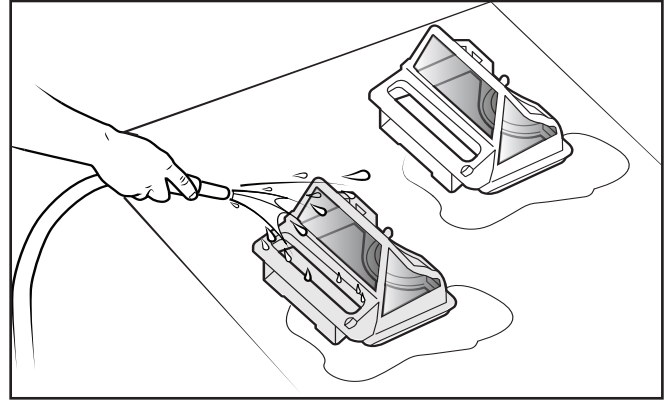

Figure 14. Wash Filter Canisters

NOTE: Periodically, deep-clean the filter canisters with soapy water and a soft bristle brush.

Section 6. Cleaner Storage

Store the cleaner when not in use.

1. Disconnect cleaner from the power source.
2. Starting at the cleaner head, remove all coils and tangles from the cable. Lay the cable in the sun to loosen any tangling memory.
3. Disconnect the cable from the Control Unit. Replace the protective cap on the Control Unit.
4. Loosely coil the power cable starting at the cleaner and moving toward the connection point at Control Unit.

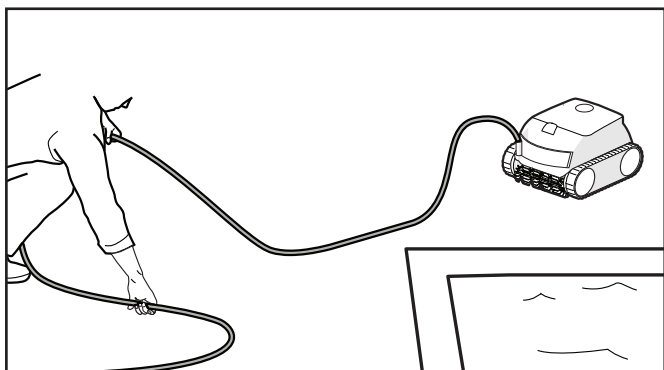

Figure 15. Untangle the power cable

NOTE: The CX50 cleaner should be stored on its caddy. Place the rear wheels on the caddy and position the cleaner vertically on the caddy base. Store the cable by wrapping it around the hook located on the front of the caddy.

Section 7. Replacing Wear Parts

To maintain cleaner performance, replace wear parts every 2 years or as needed. Replace the brushes when the rubber is worn down to the top of the wear indicator. Replace the tracks if the cleaner loses traction when climbing walls.

7.1 Replacing Brushes

The wear indicator is located on one blade as shown.

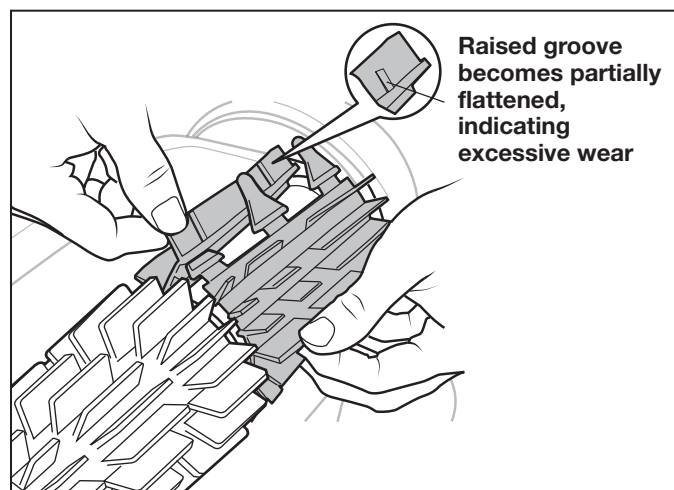

Figure 16. Worn Brush Indicator

To replace a worn brush:

1. Lift the cleaner to a vertical position so that the handle is up.

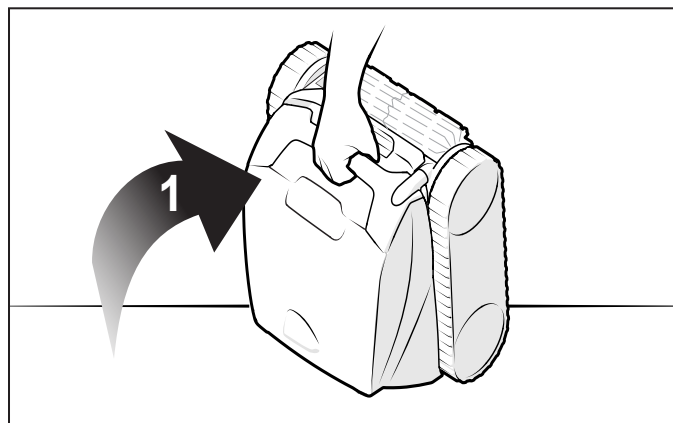

Figure 17. Cleaner in Upright Position

2. Separate the edges of the brush and undo the tabs. Remove the worn brushes.

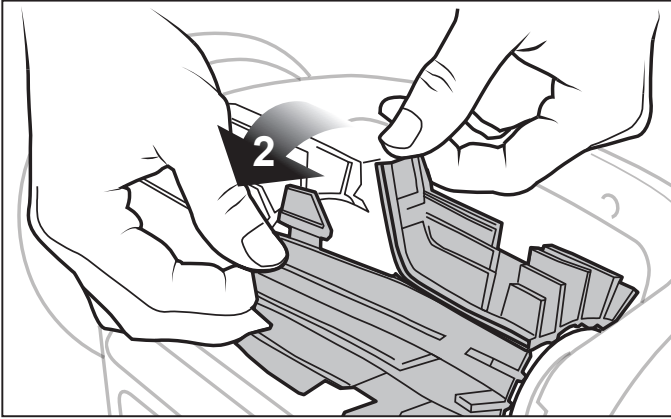

Figure 18. Undo the Tabs of the Brush

3. To install the new brush, position the new brush on the roller with the cleaning blades facing away from the roller.

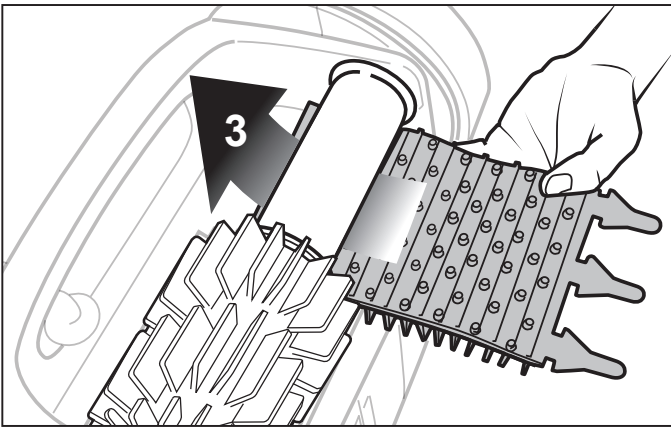

Figure 19. Install the New Brush

4. Thread each tab into the corresponding slot then gently pull tab through until the heel comes out at the other side of the slot.

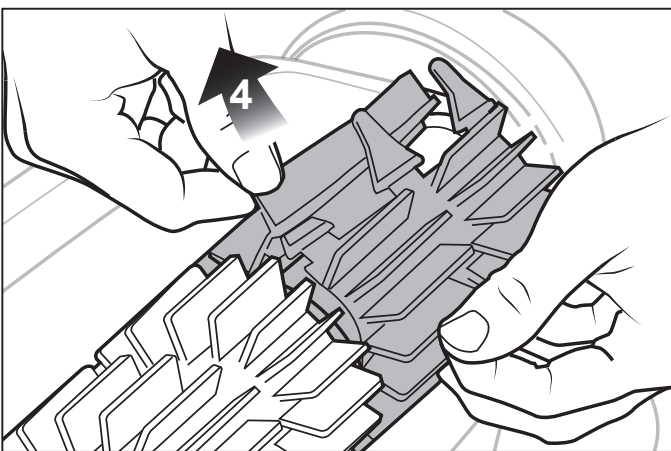

Figure 20. Pull Tabs Through Each Slot

5. Use a pair of scissors to cut the tabs 3/4 inch from the heel so that they are no higher than the cleaning blade.
6. Repeat the procedure to install the second brush.

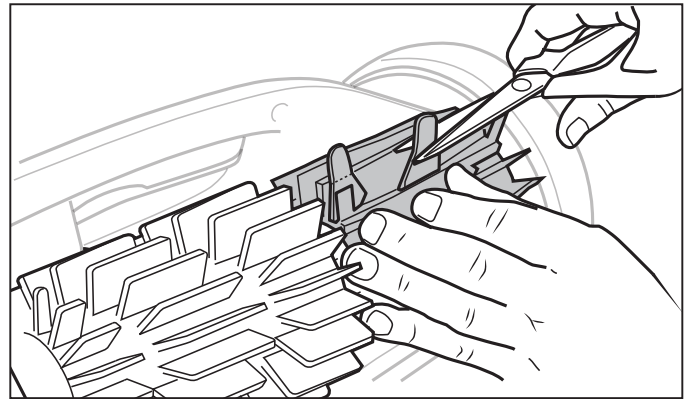

Figure 21. Cut Tabs

7.2 Replacing Tracks

1. Pull on the inside of the old track to remove the track lip from the front wheel.

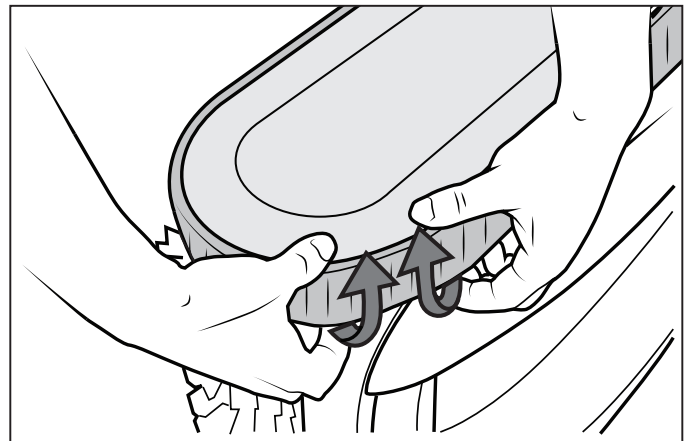

Figure 22. Pull the Old Track Over the Wheel

2. Remove the old track from the front wheel, then remove track from the rear wheel.

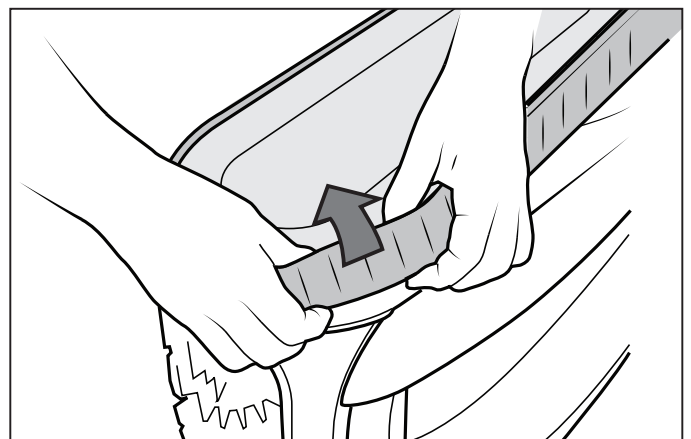

Figure 23. Remove the Old Track

3. Replace the track on the wheel by positioning the rib toward the body of the cleaner.

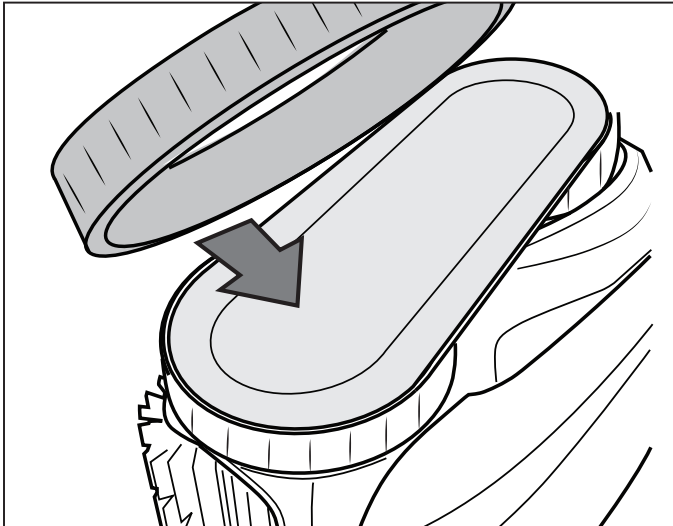

Figure 24. Track Replacement Orientation

4. Push one side of the track on to the wheel and fit the rib of the track in the groove of the wheel.

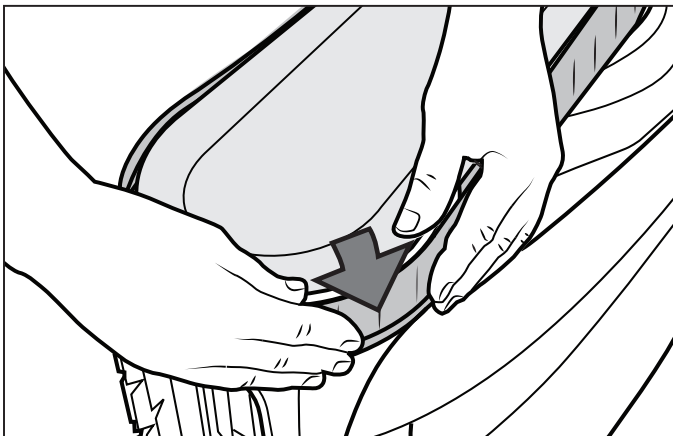

Figure 25. Start on One Side of the Track

5. Work the track onto the front wheel and verify the rib of the track is positioned properly within the groove of the wheel.

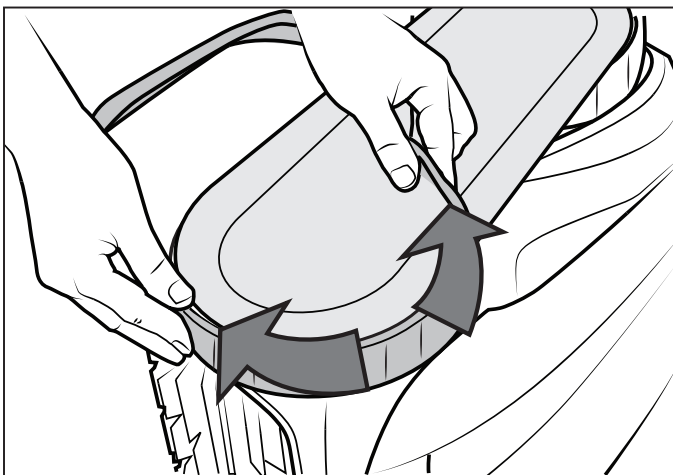

Figure 26. Work the Track On Around the Wheel

6. Push and position the rib of the inner side of the track in the groove of the rear wheel. If needed, turn the wheel gently to help with installation.

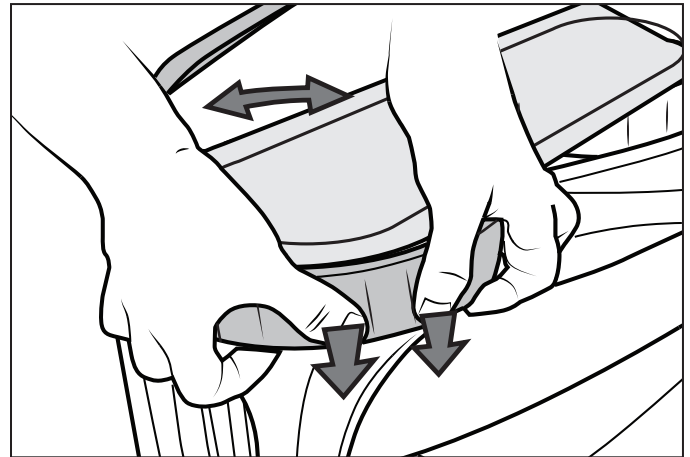



Figure 27. Push the Track into Place on the Wheel

7. Work the track onto the rear wheel and verify the rib of the track is positioned properly within the groove of the wheel.
8. Push and position the rib of the inner side of the track in the groove of the rear wheel. If needed, turn the wheel gently to help with installation.

Section 8. Troubleshooting

If the status indicator on the Control Unit flashes to alert the user, follow the recommended troubleshooting tips below.

8.1 Error Codes

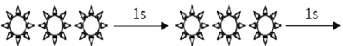
Flashing LED	Suggested Solution
 <p>1 flash / 1 second pause</p>	<ul style="list-style-type: none"> • Disconnect and reconnect the cleaner. • Check that the cable is properly connected to the control box. • Check that nothing is interfering with the cable connection area. • If this does not resolve the problem, contact your local retailer for a diagnostic review or call customer service.
 <p>2 flashes / 1 second pause</p>	<ul style="list-style-type: none"> • Check that debris or the cable is not preventing the brushes or the tracks from rotating freely. • Check that nothing is interfering with the cable connection area. • Rotate the track by a quarter of a turn in the same direction until it rotates smoothly • If this does not resolve the problem, contact your local retailer for a diagnostic review or call customer service.
 <p>3 flashes / 1 second pause</p>	<ul style="list-style-type: none"> • Turn the cleaner off. • Clean the filter thoroughly. • Put it back in the water, shaking to release the air bubbles. • Restart the cycle. • If this does not resolve the problem, contact your local retailer for a diagnostic review or call customer service. <hr/> <ul style="list-style-type: none"> • Check that no debris or hair is blocking the impeller. • Clean the filter thoroughly. • If this does not resolve the problem, contact your local retailer for a diagnostic review or call customer service.

8.2 Deleting an error code

After following the troubleshooting solutions, press any key to delete the error code.

8.3 General Troubleshooting

The following list provides some helpful hints for troubleshooting common challenges when using the cleaner.

User Issue	Possible Cause	Suggested Solution
The cleaner does not stay on the pool surface or is floating excessively.	There is air trapped inside the cleaner housing.	Remove cleaner from pool and re-submerge (see <i>Submerge the Cleaner</i>).
	The filter canister is full or dirty.	Dispose of debris and thoroughly clean the filter canister with mild soap and a soft brush. Then, re-submerge the cleaner (see <i>Clean the Filter Canister</i>).
The cleaner is not climbing walls.	The filter canister is full or dirty.	Dispose of debris and thoroughly clean the filter canister with mild soap and a soft brush. Then, re-submerge the cleaner (see <i>Clean the Filter Canister</i>).
	Confirm appropriate pool chemistry	Speak with your pool service professional. Do not leave cleaner in the pool during any chemical treatments.
The cleaner is not moving	Not connected to electricity.	The outlet the control box is connected to, is not supplying electrical power. Check that the outlet to which the control box is connected is receiving electricity.
	Cycle not started.	Press the Start button to initiate a cleaning cycle.
	Reset needed	Disconnect the unit power and reconnect after 20 seconds. If the problem is not resolved, contact your local retailer to request a diagnostic review or contact Technical Support at 1300 763 021 (NZ: 0800 807 665).
Cable is tangling in the pool.	Cable is not spread evenly in the water	Verify the floating cable enters the water near the middle of the pool length. Spread all of the floating cable carefully in the pool, ensuring there are no kinks or coils. Ensure the cable is not too tightly wrapped or coiled when storing. If the problem persists, lay the cable straight in the sun to relax it and remove kinks. Follow the procedure in <i>Cord Tangling</i> to avoid and correct tangled cord.
The cleaner is not cleaning the pool effectively.	Filter canister is full or dirty.	Dispose of debris and thoroughly clean the filter canister with mild soap and a soft brush. Then, re-submerge the cleaner (see: <i>Clean the Filter Canister</i>).
	Brushes are worn.	Check the wear indicator(s). Contact your local dealer for spare parts.
	Cable is excessively tangled.	Untangle the twisted cord and lay in sun to reduce memory (see: <i>Cord Tangling</i>).

Fluidra Group Australia Pty Ltd

1 Herbert Place, Smithfield NSW 2164
PO Box 7238 Wetherill Park NSW 1851, Australia
ABN: 87 002 641 965
Zodiac.com.au | 1300 763 021

Fluidra NZ Ltd

13 Douglas Alexander Parade
Rosedale Auckland 0632, New Zealand
NZBN: 942 903 181 70759
Zodiac.co.nz | 0800 807 665

A Fluidra Brand

©2023 ZODIAC is a registered trademark of Zodiac International S.A.S., used under license. This document is subject to change without notice.

H0830000_REVA